

# **THERMOSALD**

**SCR  
CHECK TWINLEAD  
FOR  
IMPULSES WELDING  
OF  
POLYTHENE AND PLASTIC FILM**

patent NO. BO93A 000274  
(INTERNATIONAL PATENT PENDING)

3E S.r.l.  
Via Turati n. 55 - 40134 BOLOGNA

	INDEX	Pag.	
1	DESCRIPTION	3	
	1.1 GENERAL CHARACTERISTICS	3	
	1.2 UTILIZE	3	
	1.3 PRINCIPLE OF WORKING	3	
	1.4 SECURITIES AND DIAGNOSTICS	3	
2	TECNICALS DATES	3	
3	DIAGRAMS	4	
	3.1 BLOCK DIAGRAM	4	
	3.21 PLC CONNEXIONS DIAGRAM	5	
	CONTROL CIRCUIT FEEDING		5
	POWER	5	
	ORDERS	5	
	3.22 CONTACT CONNEXIONS DIAGRAM	6	
	CONTROL CIRCUIT FEEDING		6
	POWER	6	
	ORDERS	6	
	3.31 PLC CONNEXION DIAGRAM	7	
	TWINLEAD REFERENCE CONNEXION	7	
	3.32 CONTACT CONNEXION DIAGRAM	8	
	TWINLEAD REFERENCE CONNEXION	8	
	3.42 PLC CALIBRATING AND ADJUSTAMENT DIAGRAM	9	
4	DIMENSION	10	
	SECONDARY CALCULATION TRASFORMER (V)	10	
	TWINLEAD REFERENCE CONNEXION	10	
5	CALIBRATING	10	
	WELDING OPTIMIZATION	11	
	PROTECTION	11	
	RESET ALARM	11	
6	ORDER DATES		12
7	DIMENSIONS	13	
	7.1 THERMOSALD DIMENSION 20A	13	
	7.2 TRASFORMER DIMENSION	14	
Appendix A	WELDING CYCLE	15	

THIS CATALOGUE EDITION 1994/06 CANCELS AND REPLACES ALL PREVIOUS EDITIONS. DATA AND TECHNICAL INFORMATION MENTIONED ABOVE ARE VALID AT THE TIME OF PRINTING. IN ORDER TO IMPROVE SOME TECHNICAL FEATURES, 3E S.r.l. RESERVES THE RIGHT TO INTRODUCE CHANGES WITHOUT NOTICE.

## 1 DESCRIPTION

### 1.1 GENERALS CHARACTERISTICS

THE WELDER OF IMPULSES OF FIRM 3E IS COMPOSED BY A THERMOREGULATOR FOR WIRE OR TWINLEAN RESISTANCE WHICH CONTROLS THE TEMPERATURE OF WELDING ON CLOSED

LOOP FOR COMPENCING CASUALS THERMICS DRIFTS.

A PREHATING SYSTEM PERMETS TO FETCH THE WELDER RAIL AT THE NECESSARY TEMPERATURE FOR STARTING THE PRODUCTION IN A FEW SECONDS.

### 1.2 UTILIZE

IS PARTICULARLY SUITABLE FOR WELDING OF POLYTHENE OR THE OTHERS PLASTIC MATERIALS

WHERE ARE NECESSARY PRECISION AND QUICKNESS.

### 1.3 PRINCIPLE OF WORKING

THE DEVICE PERMETS TO POST PREHATING TEMPERATURE ON THE TWINELAND AND A WELDING TEMPERATURE.

IT RECEIVES FROM THE MACHINE A COMMAND OF PREHATING AND IT GOING TO THE POSTED TEMPERATURE.

IT RECEIVES FROM THE MACHINE A COMMAND OF WELDING AND IT GOING TO AT THE TEMPERATURE OF WELDING POSTED ON THE OUTSIDE POTENTIOMETER .

### 1.4 SECURITIES AND DIAGNOSTICS

THE CARD IS PROTECTED AGAINST SHORT CIRCUIT. A CUMULATIV ALARM SIGNAL ( OPENING OF CONCTAT BETWEEN PIN 4 AND 5 OF CN3 ) ADVICES THE MACHINE THAT THERE IS A SHORT CIRCUIT.

FOR ELIMINATING THE ALARM, IT IS NECCESARY TO LIGHT AND SWITCH OFF THE CARD AND DISCONNECT THE TENSION EXISTING ON CN2.

## 2 TECNICAL DATES

CONTROL VOLTAGE ( IN PHASE WITH POWER FEEDING )	220 VAC +/- 10%
POWER FEEDING	
AMBIENT TEMPERATURE	0° C +50° C
ACCURACY	+/- 1%
DEFINIBLE PREHATING TEMPERATURE	0-100% DELLA T.MAX
DEFINIBLE WELDING TEMPERATURE	0-100% DELLA T.MAX
WELDING	ESTABLISHED BY PLC
COOLING TIME	ESTABLISHED BY PLC
PROTECTION LEVEL	IP00

3 DIAGRAMS

3.1 BLOCK DIAGRAM

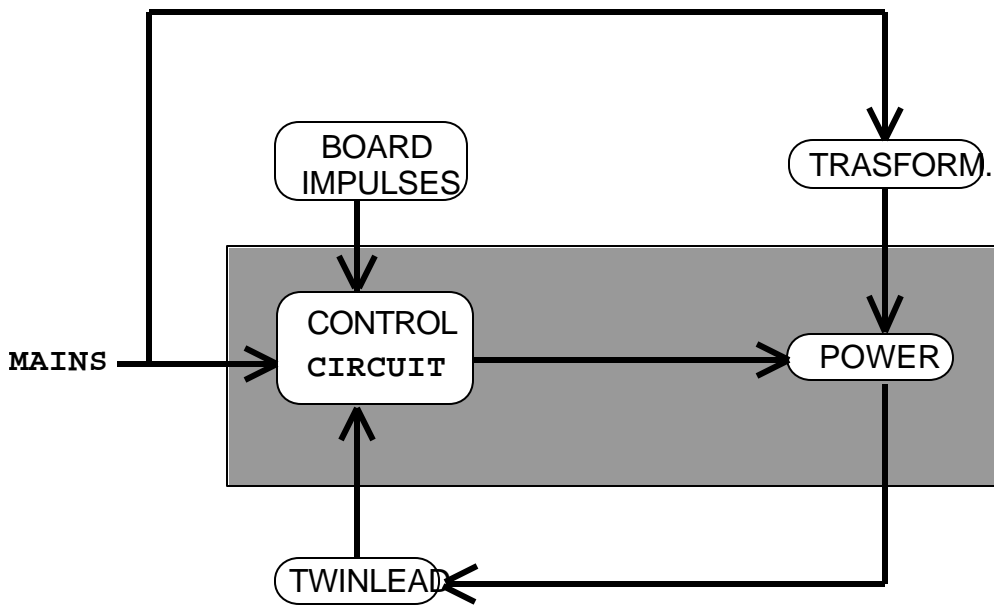

THERMOSALD BLOK DIAGRAM

**3.21 PLC CONNEXION DIAGRAM****CN1 POWER**

PIN1	ALTERNATING VOLTAGE	(4mmq)
PIN2	ALTERNATING VOLTAGE	(4mmq)
PIN3	TWINLEAD +	(4mmq)
PIN4	TWINLEAD -	(4mmq)
PIN5	GROUND	(4mmq)

**CN2 FEEDING CONTROL DIAGRAM**

PIN 1	220 Vac (0,2A) ( IN PHASE WITH POWER FEEDING )	(1mmq)
PIN 2	220 Vac (0,2A) ( IN PHASE WITH POWER FEEDING )	(1mmq)

**CN3 CONTROLS**

PIN1	COMUN	(0,5mmq)
PIN2	PREHATING CONTROL	(0,5mmq)
PIN3	WELDING CONTROL	(0,5mmq)
PIN4	WELDING ALARM (N.C. CONCTAT) 24V -1A/110V-0,5A	(0,5mmq)
PIN5	WELDING ALARM (N.C. CONCTAT) 24V -1A/110V-0,5A	(0,5mmq)
PIN6	PREHATING POTENTIOMETER TEMPERATURE (OV)	(0,5mmq)
PIN7	PREHATING POTENTIOMETER TEMPERATURE(REF.)	(0,5mmq)
PIN8	PREHATING POTENTIOMETER TEMPERATURE (+10V)	(0,5mmq)
PIN9	WELDING POTENTIOMETER TEMPERATURE (OV)	(0,5mmq)
PIN10	WELDING POTENTIOMETER TEMPERATURE (REF.)	(0,5mmq)
PIN11	WELDING POTENTIOMETER TEMPERATURE (+10V)	(0,5mmq)
PIN12	TWINLEAND MARK +10V/+40V	(0,5mmq)
PIN13	TWINLEAND MARK +20V/+80V	(0,5mmq)
PIN14	TWINLEAND MARK -10V/-40V	(0,5mmq)
PIN15	TWINLEAND MARK -20V/-80V	(0,5mmq)

'94/6

**3.22 CONTACT CONNEXION DIAGRAM****CN1 POWER**

PIN1	ALTERNATING VOLTAGE	(4mmq)
PIN2	ALTERNATING VOLTAGE	(4mmq)
PIN3	TWINLEAD +	(4mmq)
PIN4	TWINLEAD -	(4mmq)
PIN5	GROUND	(4mmq)

**CN2 FEEDING CONTROL DIAGRAM**

PIN 1	220 Vac (0,2A) ( IN PHASE WITH POWER FEEDING )	(1mmq)
PIN 2	220 Vac (0,2A) ( IN PHASE WITH POWER FEEDING )	(1mmq)

**CN3 CONTROLS**

PIN1	COMUN	(0,5mmq)
PIN2	PREHATING CONTROL ( CLEAN CONCTAT )	(0,5mmq)
PIN3	WELDING CONTROL ( CLEAN CONCTAT )	(0,5mmq)
PIN4	WELDING ALARM (N.C. CONCTAT) 24V -1A/110V-0,5A	(0,5mmq)
PIN5	WELDING ALARM (N.C. CONCTAT) 24V -1A/110V-0,5A	(0,5mmq)
PIN6	PREHATING POTENTIOMETER TEMPERATURE (OV)	(0,5mmq)
PIN7	PREHATING POTENTIOMETER TEMPERATURE(REF.)	(0,5mmq)
PIN8	PREHATING POTENTIOMETER TEMPERATURE (+10V)	(0,5mmq)
PIN9	WELDING POTENTIOMETER TEMPERATURE (OV)	(0,5mmq)
PIN10	WELDING POTENTIOMETER TEMPERATURE (REF.)	(0,5mmq)
PIN11	WELDING POTENTIOMETER TEMPERATURE (+10V)	(0,5mmq)
PIN12	TWINLEAND MARK +10V/+40V	(0,5mmq)
PIN13	TWINLEAND MARK +20V/+80V	(0,5mmq)
PIN14	TWINLEAND MARK -10V/-40V	(0,5mmq)
PIN15	TWINLEAND MARK -20V/-80V	(0,5mmq)

'94/6

3.31 PLC CONNEXION DIAGRAM

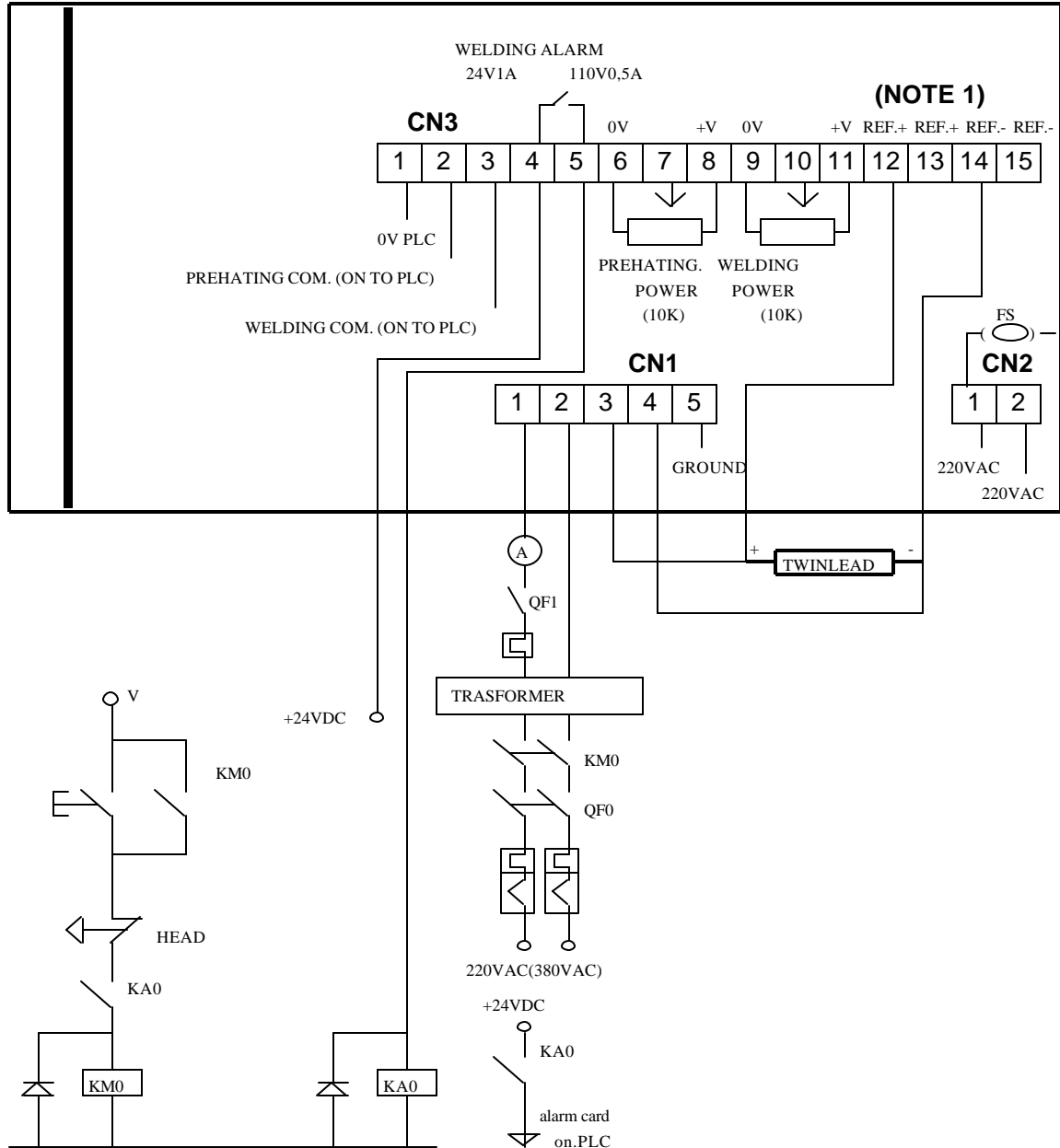

**NOTE 1 LINKING TWINLEAD REFERENCE (CN3)**

AT TERMINAL BLOCK CN3/12,14 IF TRASFORMER  $\leq 30\text{VAC}$

AT TERMINAL BLOCK CN3/12,15 IF TRASFORMER  $> 30\text{VAC}$

**N.B. TO PAY ATTENTION TO POLARITY**

**THERMOSALD-EDITION '94/6**

**3.32 CONTACT CONNECTION DIAGRAM**



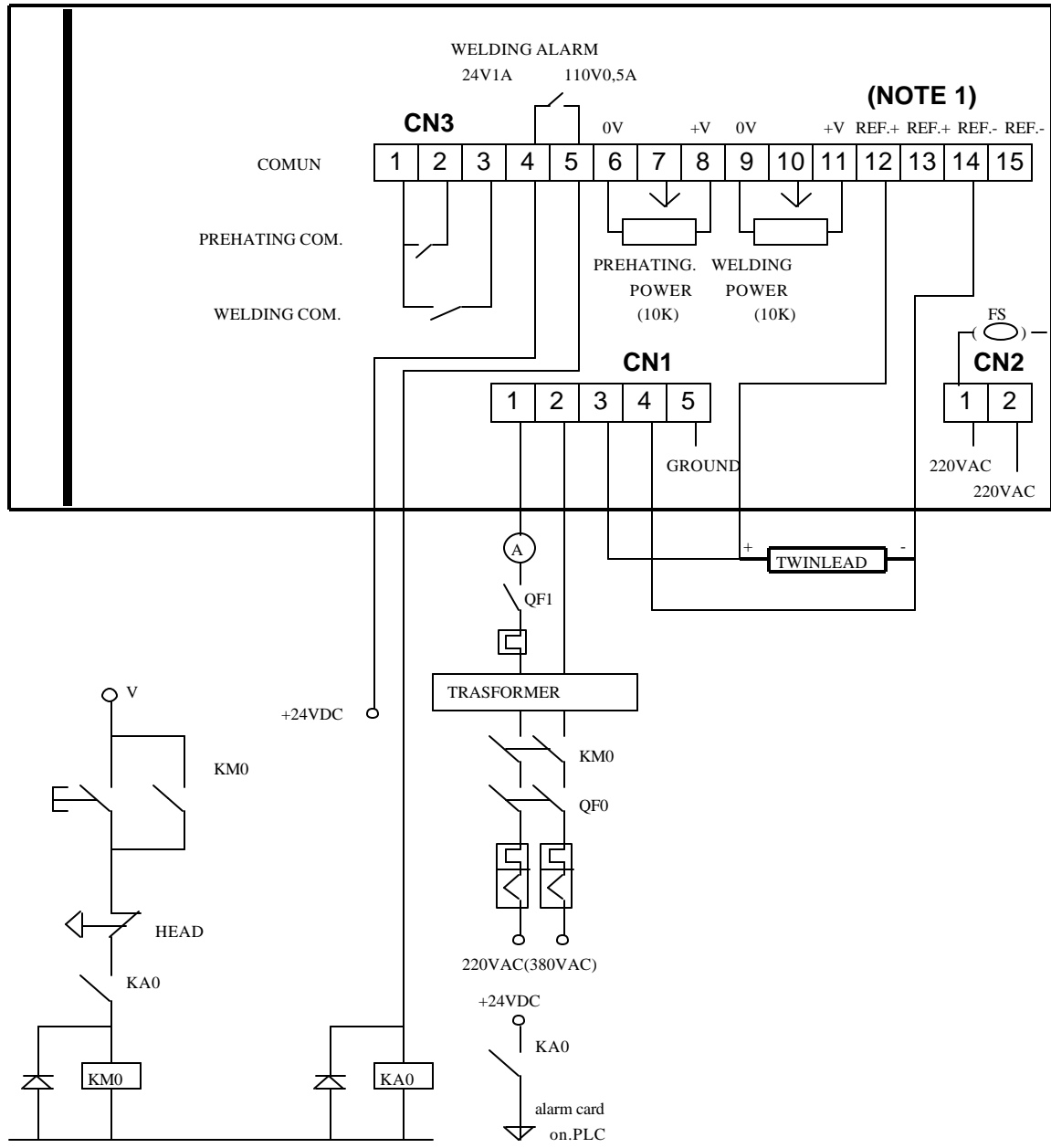

**NOTE 1 LINKING TWINLEAD REFERENCE (CN3)**  
 AT TERMINAL BLOCK CN3/12,14 IF TRASFORMER <=30VAC  
 AT TERMINAL BLOCK CN3/12,15 IF TRASFORMER >30VAC  
**N.B. TO PAY ATTENTION TO POLARITY**

### 3.42 PLC LINKING DIAGRAM

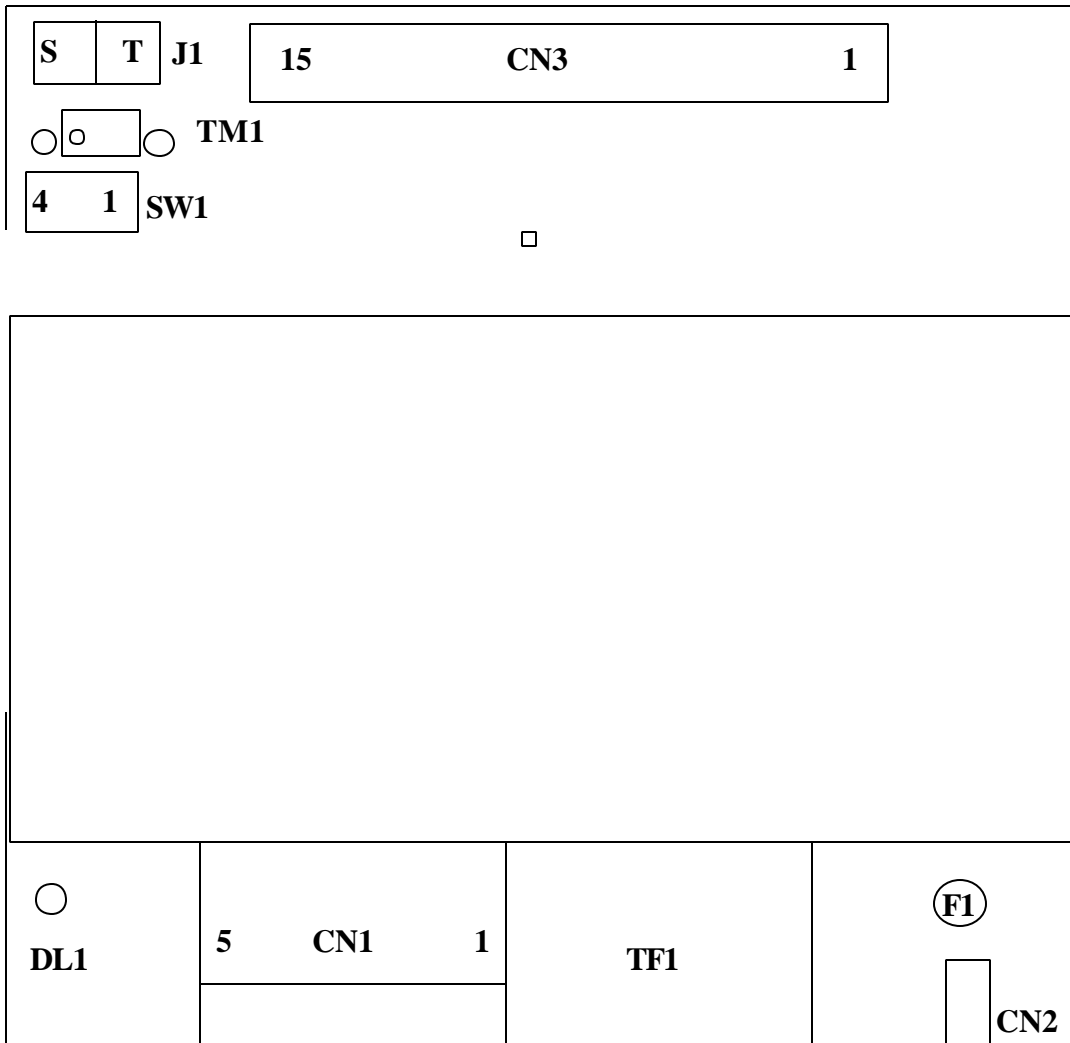

**TM1** - CALIBRATING INITIAL

**DL1** - GREEN LED OF POWER

**DL6** - GREEN LED OF CALIBRATING

**DL7** - RED LED OF CALIBRATING

**F1** - POWER FUSIBLE

**J1** - COMMUTATOR (WELDING/CALIBRATING) (SALDATURA/TARATURA)

**SW1** - DEEP SWICTH WITH STATIC GAIN ADJUSTEMENT

'94/6

**4 ELETTRICAL TRASFORMER DIMENSIONS****SECONDARY CALCULATION TRASFORMER (V) :**

READ RESISTANCE VALUE ON THE EXTREMITIES OF THE TWINLEAD  
 TAKE INTO CONSIDERATION THE NOMINAL CURRENT OF THE CARD  $I = 20A$   
 CALCULATE THE TRASFORMER SECONDARY TENSION  $V \leq R \cdot I$ .

**CONNEXION TWINLEAD REFERENCE:**

AT THE TERMINAL BLOCK CN3/12, 14 IF THE TRASFORMER  $\leq 30Vac$ .  
 AT THE TERMINAL BLOCK CN3/13, 15 IF THE TRASFORMER  $> 30Vac$

**5 CALIBRATING**

**NOTA:** POST THE STATIC GAIN OF CARD ACCORDING TO THE APPLICATION ( SEE GAIN TABLE )

**TABLE STATIC GAIN**

	1	2	3	4
GS=05	ON	ON	ON	ON
GS=10	OFF	ON	ON	ON
GS=20	OFF	OFF	ON	ON
GS=40	OFF	OFF	OFF	ON
GS=80	OFF	OFF	OFF	OFF

**NOTA : I SUGGEST YOU GS=20**

**NOTA :** EVERY TIME YOU MODIFY THE POSITION OF A BREAKER YOU MUST EFFECT AGAIN THE WELDING.

**NOTA :** THE WRITING " **ATTENTION TO AMPEREMETER** " THAT YOU CAN FOUND INTO FOLLOWING INDICATIONS, SAY THAT THE OPERATOR MUST ALWAYS CONTROL THAT THE CURRENT DO NOT AUGMENT TOO MUCH FOR AVOIDING A WRONG OPERATION. ( IN THIS CASE PRESS THE EMERGENCY HEAD ).

- 1) POSITION THE COMMUTATOR J1 ON WELDING.
- 2) TURN THE EXTERIOR WELDING AND PREHATING POTENTIOMETERS AT 0, OTHERWISE IN ANTICLOCKWISE DIRECTION .

- 2) INSERT THE PREHATING ORDER ( **ATTENTION TO AMPEREMETER** ).
  - 3) TURN THE WELDING TRIMMER TM1 TILL WHEN THE RED WELDING LED TURN OFF AND THE GREEN LED LIGHT.
  - 4) POSITION THE J1 COMMUTATOR ON WELDING ( **ATTENTION TO AMPEREMETER** ) (IT IS POSSIBLE TO VERIFY THE CORRECT FUNCTIONING OF CARD TURNING OF A FEW GRADES THE OUTSIDE PREHATING POTENTIOMETER TO CLOCKWISE DIRECTION FOR CHECKING THAT THE CURRENT AUGMENT AND TO CARRY IT BACK IMMEDIATELY AT 0 TO ANTICLOCKWISE DIRECTION ).
  - 5) INSERT THE WELDING ORDER (IN CASE MAKE SOME PLASTIC BAG) AND FOUND THE RIGHT CURRENT TURNING TO CLOCKWISE DIRECTION THE OUTSIDE WELDING POTENTIOMETER (**ATTENTION TO AMPEREMETER**).
- (IF YOU WISH TO AUGMENT AGAIN THE CURRENT YOU MUST SLOWLY TURN THE WELDING TRIMMER TM1 TO ANTICLOCKWISE DIRECTION ATTENTION BECAUSE THE REGULATION IS VERY SENSIBLE).

#### **CALIBRATING OPTIMIZATION**

(TO EXECUTE IT AFTER THE INITIAL CALIBRATING AND IN THE NEXT TUNING UP)

**NOTA BENE** : FOR A GOOD FUNCTIONING OF MACHINE THE AMPEREMETER MUST INDEX ON AUGMENT OF CURRENT EVERY TIME THAT YOU GIVE A WELDING ORDER OTHERWISE EVERY TIME THE WELDING BARS ARE CLOSING.

IF YOU WISH THAT THE CIRCUIT BECOME MORE SENSIBLE, YOU MUST REDUCE WITH MORE ATTENTION THE OUTSIDE WELDING POTENTIOMETER AND YOU MUST SLOWLY TURN THE WELDING TRIMMER TM1 TO ANTICLOCKWISE DIRECTION TILL WHEN YOU FOUND THE BEST CONDITIONS FOR WORKING.

(THE MACHINE IS READY FOR WORKING).

#### **PROTECTION**

THE CARD IS PROTECTED AGAINST SHORT CIRCUIT.

A CUMULATIV ALARM SIGNAL ( OPENING OF CONCTAT BETWEEN PIN 4 AND 5 OF CN3 ) ADVICES THE MACHINE THAT THERE IS A SHORT CIRCUIT ).

#### **RESET ALARMS**

FOR ELIMINATING THE ALARM, IT IS NECCESARY TO SWITCH OFF AND LIGHT THE CARD AND DISCONNETING THE TENSION EXISTING ON CN2 .

**NOTA BENE:** CHECK THAT THE HEAT SINK TEMPERATURE IS NOT OVER 60° C DURING THE FACTION RATE.

**6        ORDERS DATES**

THERMOSALD 7020 THERMOWELDING 50VAC/20A	3ESBOO13
ALIMENTATION TRANSFORMER 100VA (24-0-24)	3ESD0018
ALIMENTATION TRASFORMER 1400VA (0-30-40-50-60)	3ESD0029
ACCESSORIES KIT (POTENTIOMETER AND GRIPS)	3ESD0028
AMPEREMETER 30A	3ESD0035
AMPEREMETER 60A	3ESD0036

**7 DIMENSION**

**7.1 DIMENSION THERMOSALD 20A - 40A - 50A**

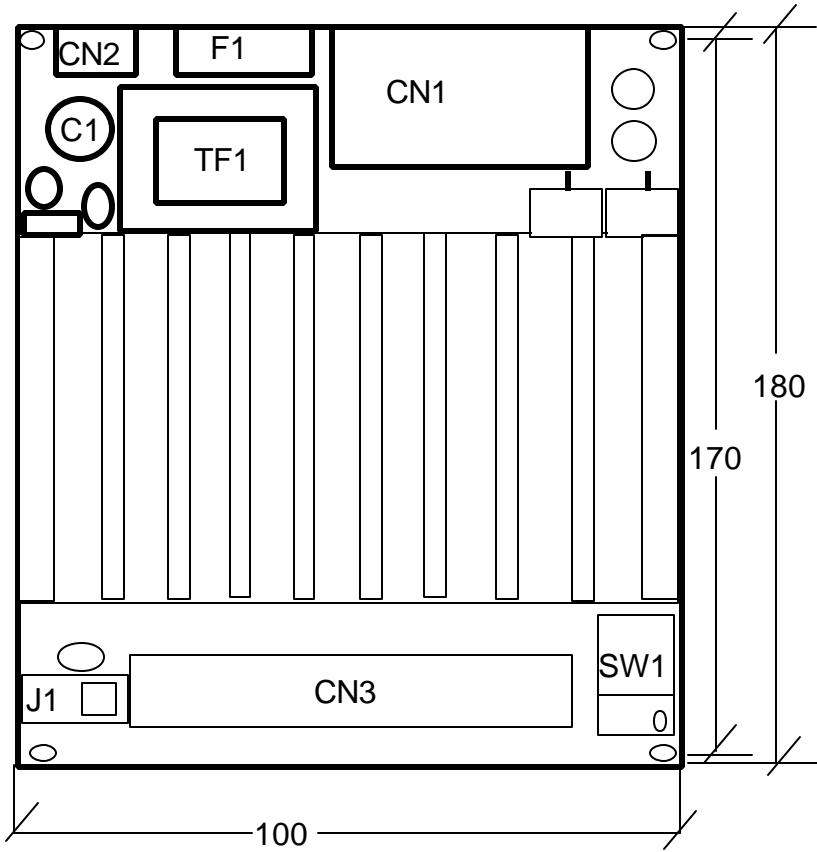
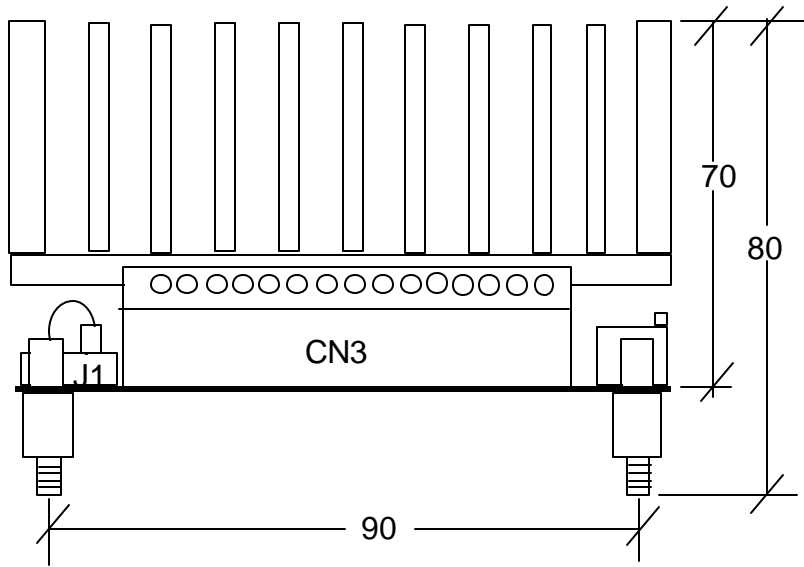

7.2 TRASFORMER DIMENSION

THERMOSALD-EDITION '94/6

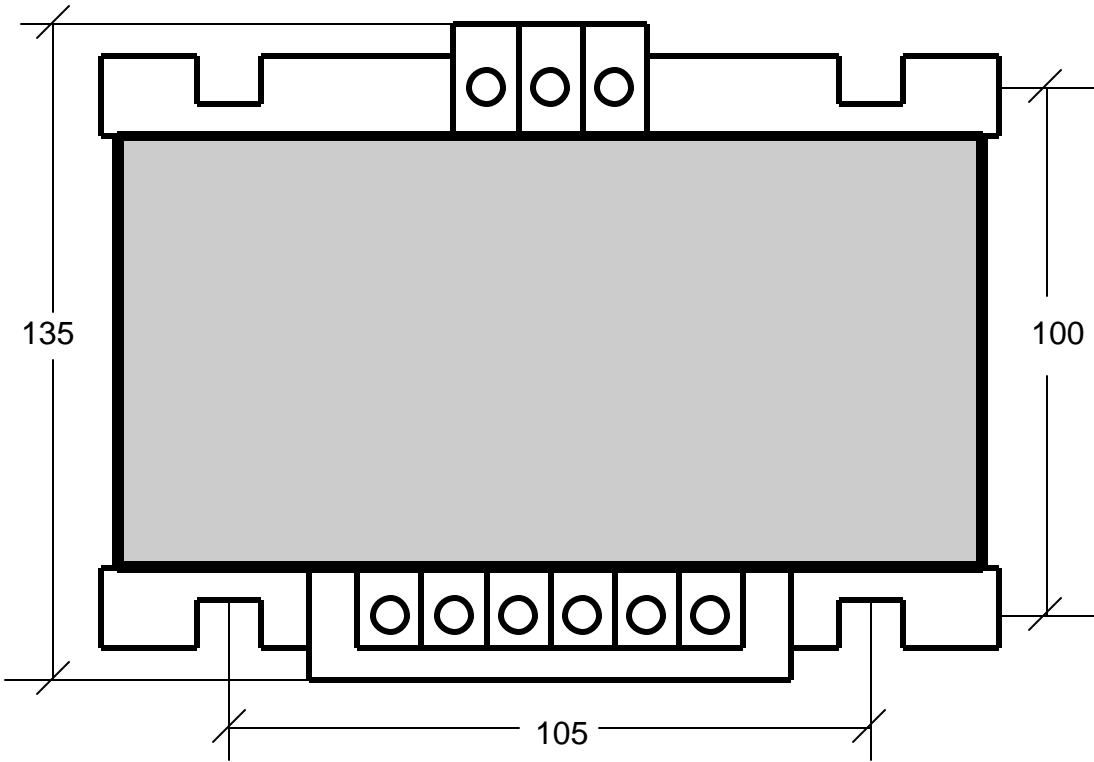
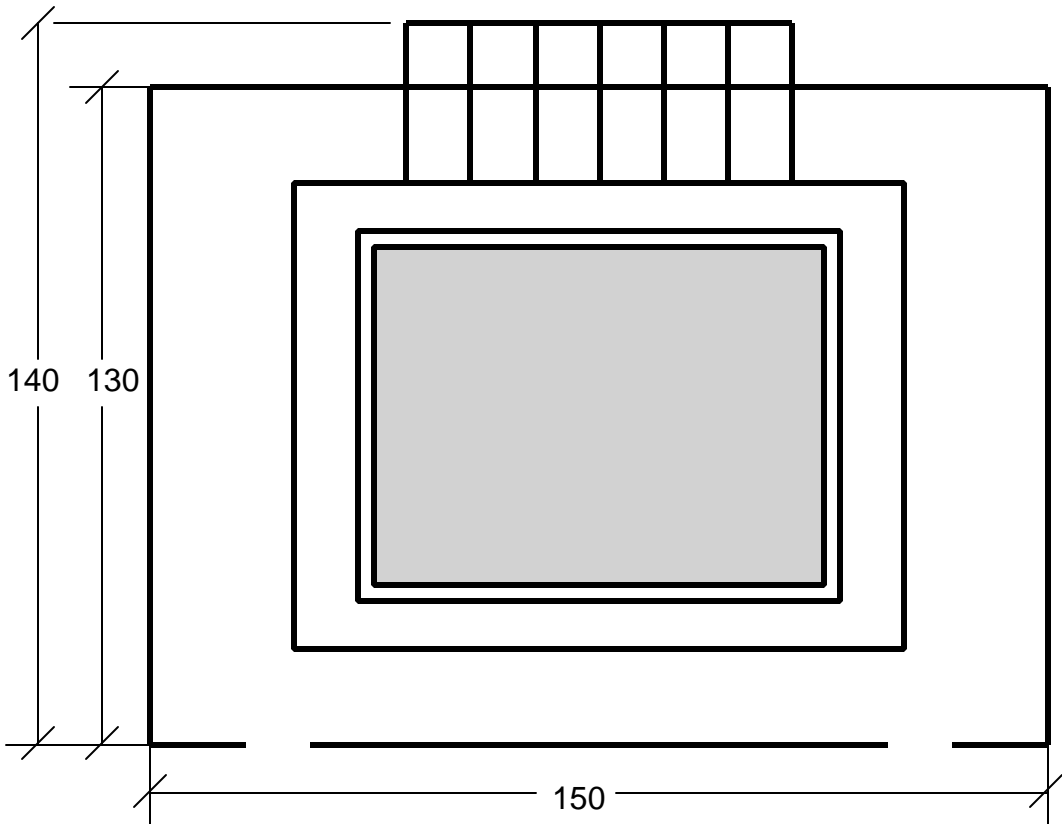

THERMOSALD-EDITION '94/6



Appendix A

# WELDING CYCLE

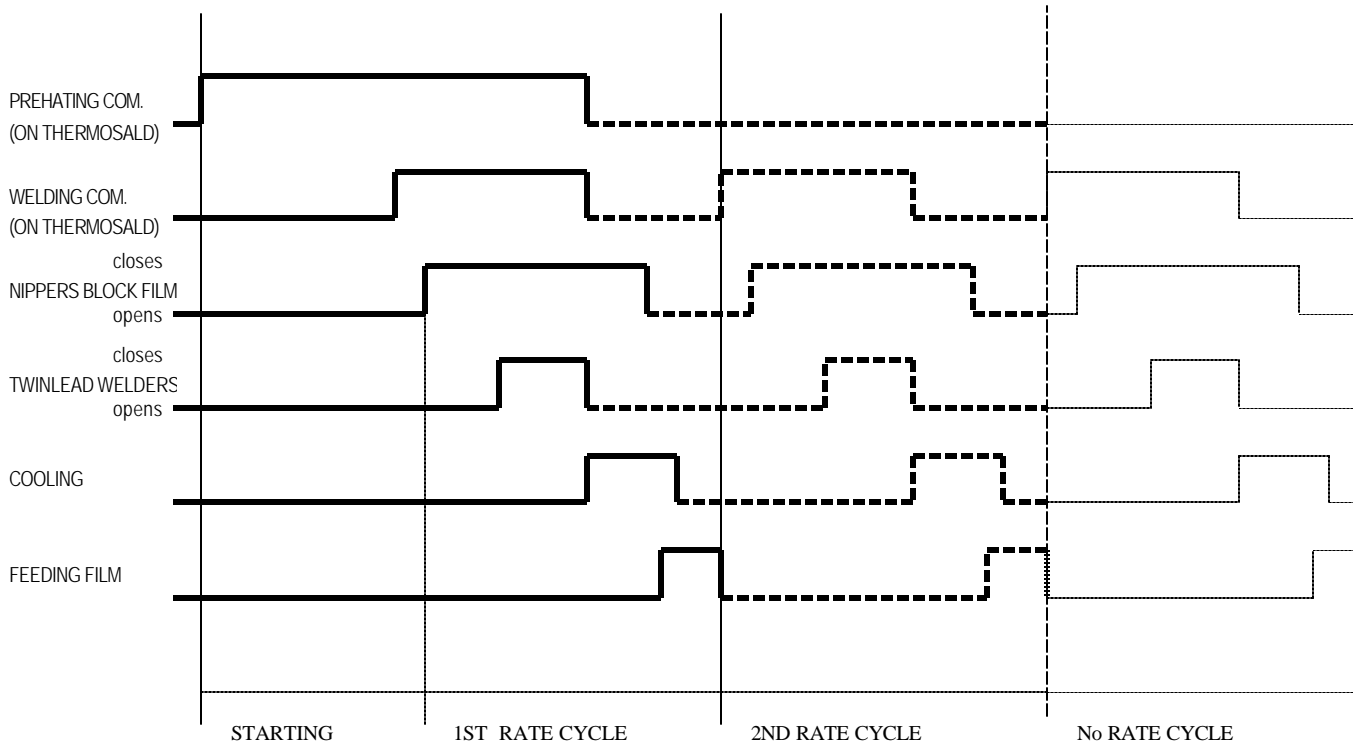

THERMOSALD-EDITION '94/6